

USEFUL
MATRIX
INFORMATION



OCTOBER, 1937

THIS BOOKLET IS LOOSELY SET ON MARSHALLS BY THE
LACOTTE WITING FAMILY AND PRINTED DIRECT FROM THE SLIDES
PRINTED IN U.S.A. 270.11.1-3-4-22X

**USEFUL
MATRIX
INFORMATION**



OCTOBER, 1937

MERGENTHALER LINOTYPE COMPANY

29 Ryerson Street, Brooklyn, N. Y.

NEW YORK CITY · CHICAGO · SAN FRANCISCO · NEW ORLEANS

CANADIAN LINOTYPE LIMITED, TORONTO

Representatives in the Principal Cities of the World

CONTENTS

MATRIX INFORMATION	PAGE
How to Order Matrices	3-5
Key to Matrix Terms	6-8
Figures	9
Leaders	9, 10
Point System	10
Matrix Bridge and Notches	11-13
Tooth Combinations, Function of	14, 15
Tooth Combination Charts	16-20
FACE IDENTIFICATION NUMBERS	
One-Letter	21-23
Two-Letter	23-42
Display	43-58
FONT SCHEMES, SUGGESTED	59-80
ACCENTED CHARACTERS	81, 82
KEYBOARD DIAGRAMS	83-107
ALL-PURPOSE LINOTYPE	
Description	110
Equipment	110
Matrix Data	111-113
List of Faces	114, 115
Font Schemes	116, 117

Useful Matrix Information

The Mergenthaler Linotype Company carries in stock a full supply of matrices to meet the exacting demands of printers throughout the world. Matrices can be supplied for composition in over seventy different languages. With the great number of different characters to be supplied, the importance of giving careful attention to accuracy of detail in preparing orders will be appreciated.

Every possible facility is provided for the proper selection and ordering of matrices according to the style of face and the characters desired. Orders should be typewritten, preferably, and the name of the face given. One copy should be retained for reference.

MATRIX ORDER FORMS

Linotype matrix order forms are supplied in any quantity, free upon request. They should always be used in ordering matrices. This enables us to fill orders correctly and promptly.

Order forms can be supplied for regular characters, accents, fractions, logotypes and other special characters, border matrices and matrix slides, as well as for all foreign characters. Always use the correct type of order form. Use one sheet for each face and point size thereof.

It is important to know the Linotype model for which the matrices are intended, as well as the particular style of magazine used. This is necessary because various Linotype models differ in so far as milling of matrix lugs and magazine limitations are concerned.

FULL NAME OF FACE

The full name of the face should always be entered at the top of each order, thus

10 point Excelsior with Italic and Small Caps; or

10 point Excelsior with Bold Face No. 2; or

10 point Excelsior with Memphis Bold

We frequently receive orders, for example, 10 point Excelsior. As shown above, this face is made in various combinations, and in such cases it is difficult to fill the order correctly without asking for further information.

(4) USEFUL MATRIX INFORMATION

TRIANGLE NUMBERS

The system of marking matrices is shown in the illustrations on page 6. The triangle is the trade-mark of the Mergenthaler Linotype Company. When uncertain of the correct name of face, matrices may be ordered according to the numerical marking on the side. The triangle number should always be entered on the matrix order form. Always copy the marking exactly, as, for instance, 10 Δ 386. Do not choose a matrix at random or take one from a pi tray to obtain the triangle marking. Select a lower case n from the face for which matrices are wanted; if figures are ordered select a figure 5. The reason for this is that reference characters, quads, leaders, special characters and fractions in some fonts bear markings different from the alphabet character.

ACCENTED CHARACTERS

The standard accents shown on pages 81 and 82 will be supplied with any standard face at the regular sorts price. Characters not shown can be made to order at a special price which will be quoted on request.

There are two ways to accommodate accents on Linotype matrices—low cap accents and high cap accents. It is the usual practice to supply the low cap form of accented character so as to avoid the use of a special mold. The character is slightly reduced so that the diacritical mark and the character will not exceed the normal height of the cap character.

When low cap accents are considered undesirable, we can supply high cap accents. The extra space required by this style of accent on a cap character of full height makes it necessary to change the aligning point of the mold so that the accent will cast flush on the smooth edge of the slug without trimming off. This makes it necessary to cast a given size on a body two points larger than standard up to 14 point and approximately 4 points larger than standard on display faces. The high cap accent mold can be used on regular composition with or without accents and the extra space above mentioned will appear on the smooth edge instead of the ribbed edge of the slug.

High cap accents cannot be cast in display faces larger than 32 point, as full 36 point body is required for the cap character and its accent. Where caps only are used, high cap accents can be cast in display faces up to 36 point.

FRACTIONS

In ordering fractions, always state whether they are to run in the regular channels of the magazine or as sorts. Unless otherwise specified, they will be furnished as sorts.

Also mention whether fractions are required on an em or en body. Unless otherwise ordered, they are all furnished on an em body.

SUPERIOR AND INFERIOR CHARACTERS

When these characters are ordered, a sample character should accompany the order. This will enable us to fill the order accurately.

SPECIAL CHARACTERS

Special characters are frequently ordered from our specimen books. These specimen books contain individual showings of Linotype faces, each bearing different publication dates. Since the advent of our Universal Classification in 1923, all character numbers as shown in the specimen books prior to the Universal Classification lists have been discontinued. Therefore, when ordering a special character by number the source from which the character number is taken should always be entered on the order under "Remarks."

WHERE CHARACTERS WILL RUN

In the latter part of this booklet a complete list of display faces is given, together with the magazines in which they can be run, providing the standard keyboard layout is used. When display characters are ordered, these charts should always be consulted to see if the face will run in the magazine desired.

When characters are ordered to run in a magazine other than according to the standard layout, information should always be given as to where the displaced characters are to run. Attention is called to the fact that when a character runs in a different channel than standard, the character which is displaced must naturally be run in another location or sorts.

KEY TO MATRIX TERMS

In order that the terms and functions of various parts of a matrix may be readily understood, we present the diagrams shown below:

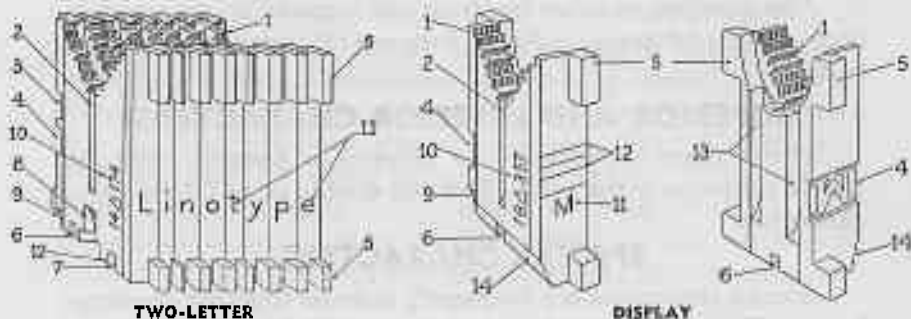

1. TEETH

Projections on the inside of the triangular opening at the top of the matrix. There are seven of these teeth on either side. The teeth which are left in are called the tooth combination. As the matrix travels along the distributor bar, it is supported by corresponding teeth on the bar. At a predetermined point, the teeth on the bar are cut away. The matrix, being no longer supported, drops through the channel entrance and to its proper place in the magazine. A matrix with all the teeth in is called a "pi" matrix, and passes all the combinations on the distributor bar, falling down the pi chute to the pi stacker.

2. BAR POINT SLOT

This is a slot projecting downward toward the bottom of the matrix. The object is to make all matrices of the same thickness at this one point. The slot registers with the projecting blade on the distributor box bar to prevent the lifting of two matrices at one time into the distributing screws.

3. REGULAR POSITION

This denotes the character in the regular or normal position of a two-letter matrix. Matrices from 4 to 24 point can be supplied with two characters. Above 24 point only one character can be used.

4. AUXILIARY POSITION

This denotes the character in the auxiliary or raised position. Characters on one-letter display matrices 16 to 60 point are also in the auxiliary position.

5. LUGS

These are sometimes called "ears." They are made to a certain thickness according to the magazine channel in which the matrix is to run. The lugs are the guiding points of the matrix throughout its travel. The lower lug (on the character side) determines the horizontal alignment of the character in the matrix, for this lug banks against the aligning groove in the mold body.

6. FONT SLOT

This is a small slot in the bottom of the matrix for use on single distributor machines. In conjunction with the automatic font distinguisher, it prevents wrong fonts from entering the magazine.

7. BRIDGE NOTCH

A slightly larger opening than the font slot. It is used in conjunction with the matrix bridge on multiple distributor Linotypes to permit the matrix to distribute to its proper magazine.

8. BEVEL NOTCH

A notch cut in matrices for Models such as 9, 16 and 17, and used to prevent two matrices from being lifted at one time into the distributor screws.

9. CLEARANCE CUT

This is a feature of Linotype matrices. It protects the side walls of matrices as they are assembled.

10. TRIANGLE NUMBER

The triangle is the trade-mark of the Mergenthaler Linotype Company. The number before the triangle indicates the point size of the matrix. The number after the

(8) USEFUL MATRIX INFORMATION

triangle indicates the name of the matrix face. The entire marking should always be given when ordering matrices.

11. REFERENCE MARKING

These are characters punched in the reference side of the matrix to enable the operator to read the line of matrices as they are assembled.

12. FACE LINES

These are lines cut in the bottom of two-letter matrices (and on the reference side of display matrices) to identify the font. When matrices of a two-letter font are stacked in a sorts tray, the various lines match up and tell at a glance whether a wrong font matrix is present. With display faces, wrong font matrices can be detected in the sorts tray or the assembling elevator, since the face lines are on the reference side of the matrix.

13. LIGHTENING GROOVES

As the name implies, these grooves are cut in large matrices to lighten them. On extra large matrices a lightening hole is used instead of a slot.

14. BEVEL CUT

An angle cut used on larger matrices to permit proper distribution.

FIGURES

The largest figure which will run in regular figure channel of the standard 90-channel magazine is .1107 wide; in the 72-channel magazine, .2075; in the wide 72-channel magazine, .249; in the 28-channel auxiliary magazine, .218; in the 34-channel auxiliary magazine, .249 in left side and .221 in right side; in the wide 34-channel auxiliary magazine, .315 in left side and .311 in right side. The largest figure that will run in a 90-channel magazine according to the Advertising Figure Layout is .166. Size of figures in all faces is indicated in matrix data on all specimen sheets.

It is important to note the design of the three styles of figures available with old style faces: modern, old style, and modernized. The style desired should always be specified on supply orders and machine specifications.

MODERN FIGURES

1 2 3 4 5 6 7 8 9 0

Modern figures have a common alignment, that is, are all of the same height, and have the characteristics of modern type faces—square serifs, contrasting thick and thin strokes, and, in most cases, larger body per point size. They are not ordinarily used with old style faces.

OLD STYLE FIGURES

1 2 3 4 5 6 7 8 9 0

Old style figures have ascenders and descenders, and have the modeled serifs and tapering thick and thin strokes characteristic of old style type faces.

MODERNIZED FIGURES

1 2 3 4 5 6 7 8 9 0

Modernized figures are old style figures brought to a common alignment, with the shapes of the 1, 2 and 0 changed accordingly.

LEADERS

Leaders of various styles have been designed to meet the major requirements of the trade.

Regular Leaders.—Regular leaders match the weight of face with which they are used and cast type high. Furnished in round dot or hyphen style in two, four or six dots or strokes to the em.

Universal Leaders.—Universal leaders are for Book and Jobbing work. The weight of the dot or stroke is uniform in all point sizes regardless of the style of the face with which they are used. These leaders are .003 shallower than type high, so they will not punch through the paper in printing. Universal round dot leaders are furnished two, four and six dots to the em. Universal hyphen leaders are furnished in two and four strokes to the em.

Thin Leaders.—Thin leaders are used with either of the above styles for close justification when only one spaceband is used in the line. Available in quarter-em widths in round dot or hyphen style, 8, 10, 12 and 14 point sizes.

Newspaper Leaders.—The regular round dot or hyphen leader .005 shallower than type high to minimize punching through the paper. Furnished in two, four or six dots or strokes to the em.

Newspaper Radial Leaders.—Round dot style only, and are made with a rounded or radial printing surface to prevent perforating paper and damaging press blankets. .005 shallower than type high. Furnished in two dots to the em.

(10) USEFUL MATRIX INFORMATION

Leader Aligning Dashes.—Cast a continuous unbroken line. Useful for jobbing work. Can be supplied in all standard alignments in uniform set-widths of 2, 3 and 12 points. Also available in en and em widths as substitutes for regular dot or hyphen leaders.

Jobbing Leaders.—Made in 6, 8, 10, 12 and 14 point alignments, two and four strokes, and on 6 and 12 point set-width only. The weight of the stroke and the set-width of the character is uniform in all point sizes.

POINT SYSTEM

Sizes of Type		Decimal Measurements of Bodies From 1 to 72 Point			
Excelsior	3 point	1.....	.01383	18.....	.249
Brilliant	4 point	2.....	.0277	20.....	.2766
Diamond	4½ point	3.....	.0415	22.....	.3044
Pearl	5 point	4.....	.0553	24.....	.332
Agate	5½ point	4½.....	.0622	26.....	.3596
Nonpareil	6 point	5.....	.0692	28.....	.3874
Minion	7 point	5½.....	.0761	30.....	.415
Brevier	8 point	6.....	.083	32.....	.4428
Bourgeois	9 point	7.....	.0968	34.....	.4703
Long Primer	10 point	8.....	.1107	36.....	.498
Small Pica	11 point	9.....	.1245	40.....	.5532
Pica	12 point	10.....	.1383	42.....	.581
English	14 point	11.....	.1522	48.....	.664
		12.....	.166	54.....	.747
		13.....	.1798	60.....	.830
		14.....	.1937	66.....	.913
		15.....	.2075	72.....	.996
		16.....	.2214		

Thickness of Leads and Slugs			
12 to Pica..	.01383	6 to Pica..	.0277
10 to Pica..	.0166	4 to Pica..	.0415
8 to Pica..	.0207	2 to Pica..	.083

Point System.—Prior to about 1886, each typefounder was a law unto himself in the matter of type standards. Brevier, for example, made by one foundry would not justify with brevier from another foundry. The pica "em" in use up to that time had been obtained by dividing an inch into six parts, equaling, decimally, $.166\frac{2}{3}$ ". When the present point system of the American Type Founders' Association was decided upon in 1886, the fraction was eliminated and a standard "pica" em adopted, measuring $.166$ ". This standard of measurement is used by the Mergenthaler Linotype Company, and one-twelfth of the pica, $.166$, equals one point, $.01383$. One-quarter of a point is the unit used in the manufacture of our matrices on the point-set system.

Didot System.—The Didot point measures $.01483$ of an inch. The Didot unit is the Cicero, which equals 12 corps, or $.178$ of an inch. The American (Linotype) unit is the pica em, measuring 12 point, or $.166$ of an inch. The Didot system of measurement is used in France and in most of the countries of continental Europe, and is commonly known as the French system.

Mediaan System.—The Mediaan point measures $.01374$ of an inch, and the Mediaan em or Cicero $.1649$ of an inch. This point system is used in Belgium. Mediaan height to paper is $.934$.

MATRIX BRIDGES FOR MODELS 25, 26 AND TWO-MAGAZINE MODELS 29 AND 30

The standard bridge-cutting of matrices for the above types of machines, unless otherwise specifically ordered, consists of three notches, comprising any between Nos. 2 and 7 inclusive, with the exception of the one carrying notches 5-6-7, which is not desirable. This cutting refers to the upper magazine only. Matrices for the lower main and auxiliary magazines will be unnotched unless otherwise ordered. Matrices for the upper auxiliary magazine will be cut with notches 2 to 7, inclusive, in order to drop on any bridge in use. A matrix with a combination which does not correspond with the bridge projections in use (also an unnotched matrix) will ride across the bridge, to the upper distributor box and into the lower magazine. The possible bridge combinations are listed below:

POINT SIZE OF MATRIX	BRIDGE NO.	BRIDGE NOTCHES	POINT SIZE OF MATRIX	BRIDGE NO.	BRIDGE NOTCHES	
5½, 9, 18, 36, 54	351	2-3-5	6, 6¾, 7, 10½, 11½, 12, 14, 21, 24, 28, 42, 48	365	4-5-6	
	358	2-5-7		366	2-5-6	
	361	3-5-7		368	2-4-6	
	363	2-4-5				
	364	3-5-6		4, 6½, 7½, 8, 10, 13, 16, 20, 27, 30, 32, 60	354	2-3-7
	365	4-5-6			355	2-4-7
	366	2-5-6			356	3-4-7
	369	4-5-7			357	3-6-7
	370	3-4-5			358	2-5-7
					359	2-6-7
		360	4-6-7			
		361	3-5-7			
		369	4-5-7			
			362		*2-3-4	
6, 6¾, 7, 10½, 11½, 12, 14, 21, 24, 28, 42, 48	352	2-3-6	5, 11, 22, 34			
	353	3-4-6				
	357	3-6-7				
	359	2-6-7				
	360	4-6-7				
	364	3-5-6				

*In addition to bridge No. 362, any of the bridges specified for the various point sizes can be used, except those having a No. 7 notch.

Note:— Every combination selected must include bridge notch corresponding to respective font slot of matrices, as indicated below:

FONT SLOT	CORRESPONDING BRIDGE NOTCH	FONT SLOT	CORRESPONDING BRIDGE NOTCH
5½, 9, 18, 36, 54 Point	5	4, 6½, 7½, 8, 10, 13, 16, 20, 27, 30, 32, 60 Point	7
6, 6¾, 7, 10½, 11½, 12, 14, 21, 24, 28, 42, 48 Point	6	5, 11, 22, 34 Point	8

MATRIX BRIDGE AND NOTCHES FOR FOUR-MAGAZINE MODELS 29 AND 30

The separation of matrices in the four-magazine mixer Models 29 and 30 is controlled by a single bridge projection which is positioned by an indicator dial. Since only two adjacent magazines can be in operating position at one time, it is merely necessary to position the single bridge projection to correspond to a notch in the matrices in the upper position, which notch does not appear in the matrices in the lower position. The matrices from the upper magazine will then drop on the bridge and pass to the upper magazine while the matrices from the lower magazine will ride across the bridge and pass to the lower magazine.

The location and size of the bridge notches for matrices to run in these models, is the same as for those used on Models 25 and 26. Only one notch is used for separation. The standard notching, unless otherwise specifically ordered, consists of three notches, comprising any between 2 and 7 inclusive.

(12) USEFUL MATRIX INFORMATION

The font slot of Single Distributor matrices can also be used to separate matrices in these machines, by making use of a different portion of the indicator dial.

To use Model 9 matrices in these machines it is necessary to replace the indicator dial by one designed for use with Model 9 matrices.

In order to identify the bridge notches and font slots cut in the bottom of matrices, full size reproductions of matrices are given below. These reproductions can be used as templates to determine the number of the notches or slots as an aid in positioning the single bridge projection.

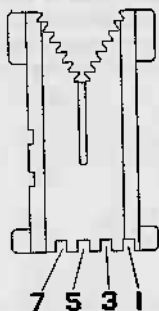

BRIDGE NOTCHES
Models 25, 26, 29 and 30

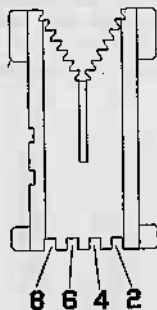

BRIDGE NOTCHES
Model 9

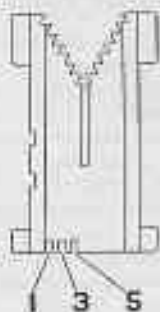

FONT SLOT
Used on single distributor
machine matrices

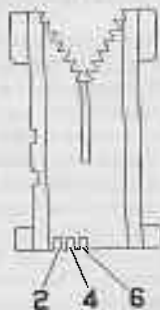

MATRIX BRIDGE AND NOTCHES (13)

The font slot numbers for various point sizes of single distributor matrices are as follows:

FONT SLOT NO.	POINT SIZES
1	5, 11, 22, 34
2	6½, 10, 13, 20, 26, 30, 60
3	4, 7½, 7¾, 8, 16, 27, 32
4	4¾, 6¾, 7, 11½, 14, 21, 28, 42
5	6, 10½, 12, 24, 48
6	5½, 9, 18, 36, 54

MATRIX BRIDGES FOR MODEL 9

Matrices on the Model 9 are separated in the primary distributor for the various magazines by means of small bridges having different combinations of projections.

All matrices used in the Model 9 must have the beveled notch, in addition to the bridge notches for separating fonts for the various magazines. All sorts matrices are supplied without bridge notches. These pass to the sorts stackers through the sorts tube.

The various bridge combinations are listed below:

BRIDGE		NOTCHES	BRIDGE		NOTCHES
OLD	NEW		OLD	NEW	
1	...	1-2-8	24	...	1-5-8
2	...	1-2-3	25	102	2-3-5
3	103	2-5-8	26	126	2-4-6
4	...	1-2-5	27	111	2-4-7
5	...	1-2-6	28	109	3-4-8
6	...	1-3-6	29	124	2-4-5
7	...	1-4-6	30	112	3-4-7
8	108	2-3-6	31	118	2-4-9
9	...	1-3-4	32	107	3-4-6
11	...	1-2-7	33	...	1-7-8
12	...	1-3-7	34	101	2-7-8
13	...	1-4-7	35	115	3-7-8
14	114	2-3-7	36	116	4-7-8
15	...	1-3-8	37	...	1-6-7
16	...	1-4-8	39	105	2-6-7
17	117	2-3-8	40	106	3-6-7
18	...	1-2-4	41	113	4-6-7
19	119	3-4-5	42	127	6-7-8
20	120	3-5-8	..	104	2-5-6
21	121	4-5-8	..	122	3-5-6
22	...	1-3-5	..	123	4-5-6
23	...	1-4-5	..	125	5-6-7

Note:—Every combination selected must include bridge notch corresponding to respective font slot of matrices, as indicated below:

FONT SLOT	CORRESPONDING BRIDGE NOTCH	FONT SLOT	CORRESPONDING BRIDGE NOTCH
5, 11, 22, 34 Point	8	4, 7½, 8, 16, 27, 32 Point	6
6, 6¾, 7, 10½, 11½, 12,	5	6½, 10, 13, 20, 30, 60 Point	7
14, 21, 24, 28, 42, 48 Point		5½, 9, 18, 36, 54 Point	Font Slot cut out by bevel

MATRIX TOOTH COMBINATIONS THEIR FUNCTION IN MATRIX DISTRIBUTION

The dictionary gives as one of the definitions of the word "matrix," "a mold in which printers' letters are cast." Immediately the matrix assumes a position of paramount importance to the printer, for he realizes, above all others, that the ultimate value of the printing process lies in the perfection of the type mold, or matrix. The printer, whatever his field of activity, restricted or general, has found a new joy in the beauty of the old designs and a new interest in the sparkle of the "moderns." All that is finest in typography has been made available to him in the form of the Linotype matrix, and with a distinct saving of his time and money. This saving has, in no small measure, been due to the elimination of the time-wasting methods of hand distribution.



Linotype matrix distribution is, in many ways, the most ingenious part of the whole machine. It has been achieved through the use of matrix tooth combinations, each character running in the magazine having its own particular combination. The term "tooth combination" refers to the teeth on the insides of the triangular opening at the top of the matrix. There are seven of these teeth on each side, and for convenience in referring to them, they are numbered from 1 to 7, as illustrated. The teeth on both sides are numbered alike, and, in cutting combinations, both of like number would be cut out or left in, as the case might be.

In conjunction with the tooth combinations there is a distributor bar, along which the matrices are carried by revolving screw action. When the combination of a given matrix arrives at and meshes with its complementary distributor bar segment, the matrix is released from the bar and falls by gravity into its respective magazine channel. That is the whole secret of Linotype distribution.

A matrix with all its teeth is called a "pi" matrix. It does not drop in any of the magazine channels, but is carried across the full length of the bar, and drops into a tube, through which it falls, by gravity, to the sorts stacker.

The primary function of the matrix teeth is, then, to direct the return of the matrix to the magazine channel assigned to it. A secondary function of the teeth is to provide the means for elevating the matrix to the distributing mechanism and guiding it on to the distributor bar.

In order to cause the matrices to drop into their respective channels, certain of the combination teeth must be removed. This is called "cutting the combination." By cutting away some of the teeth and leaving others in the matrix, it is possible to secure 126 different tooth combinations for controlling the distribution of a like number of different matrix characters to the channels of the main and auxiliary magazines. The standard Linotype magazine contains 91 channels, including an extra channel for lower case "e," and the wide auxiliary magazine 34 channels, to each of which is assigned a different combination of matrix teeth and a corresponding combination on the distributor bar.

In the charts the combinations are given for the channels of the various magazines. The figures given indicate the teeth that are left in the matrix, the others being cut out. The charts also give the number of each channel, from left to right, the lug channel size, and the character which usually runs in each channel.

TO SAFEGUARD MATRIX TEETH

To enable the matrix to travel from one position or transfer point to another with a maximum of smoothness and with a minimum of friction and resultant wear, the teeth must be perfectly proportioned with relation to the functions they are designed to perform. The teeth of the matrix, the teeth of the second elevator and distributor box bars, and the segments of the distributor bar are necessarily interdependent and inseparable in maintaining a perfectly coordinated distributing mechanism.

The matrix combination is sufficient under ordinary conditions to last for years. It is possible, however, to ruin a set of matrices in a very short time by burring or wearing out the combinations. The cause of the combinations becoming injured is invariably due to bad alignment at one or possibly all of the various transfers.

There are three of these transfers; that is to say, the matrices are transferred at three distinct points where the teeth are involved.

The first transfer is from the first elevator jaw to the second elevator bar at the intermediate channel. A matrix, when in position in the first elevator jaw at this transfer point, should line up with the bar so that you will have a perfect transfer on to the bar, without binding. There is a set screw at the bottom of the first elevator slide, on the right hand side, for raising or lowering the slide. The alignment of the first elevator jaw rails and the intermediate channel rails should be perfect. This will take care of the vertical alignment. Then, to take care of lateral alignment at the point where the matrix is supported by the first elevator jaw rails and is just sliding on to the second elevator bar, there is an intermediate channel front plate extension which, by means of screw bushings, makes it possible to move the second elevator bar either toward the front or the rear, as may be desirable to secure a true aligning condition of matrix teeth and bar. This is one of the most important adjustments from the standpoint of the matrix teeth. The second elevator bar should, of course, be perfectly smooth and free from burrs, as should be the other two bars along which the matrix must travel.

The second transfer is from the second elevator bar to the distributor box bar. The second elevator, when in its normal position, should be so adjusted that the second elevator bar will line up with the distributor box bar. This is a doweled factory setting and ordinarily should give no concern.

The third transfer is from the distributor box rails to the distributor bar. These rails should be perfectly square with one another. Place a matrix on the distributor box rails and raise up the outside distributor screw; turn the distributor screws slowly by hand and see that the matrix when supported on the distributor box rails will transfer freely on to the distributor bar. This adjustment is likewise factory-set. It does not shift under ordinary working conditions.

Perfect alignment should be maintained at all the above mentioned points. It is to the advantage of the Linotype user, in the interest of the long life of his matrices, to occasionally check these adjustments and to make any slight corrections that may be found necessary.

(16) USEFUL MATRIX INFORMATION**TOOTH COMBINATION CHART
90-CHANNEL MAGAZINE**

CHAN. NO.	CHAN. SIZE	CHAR.	TEETH IN COMBINATION	CHAN. NO.	CHAN. SIZE	CHAR.	TEETH IN COMBINATION
0	.050	e 1st	2	46	.055	En Leader	5-6
1	.050	e	1-2	47	.040	Apostrophe	1-5-6
2	.050	t	3	48	.055	Asterisk	2-5-6
3	.060	a	1-3	49	.055	l	1-2-5-6
4	.050	o	2-3	50	.055	2	3-5-6
5	.040	i	1-2-3	51	.055	3	1-3-5-6
6	.060	n	4	52	.055	4	2-3-5-6
7	.050	s	1-4	53	.055	5	1-2-3-5-6
8	.060	h	2-4	54	.055	6	4-5-6
9	.050	r	1-2-4	55	.055	7	1-4-5-6
10	.060	d	3-4	56	.055	8	2-4-5-6
11	.040	l	1-3-4	57	.055	9	1-2-4-5-6
12	.070	u	2-3-4	58	.055	0	3-4-5-6
13	.060	c	1-2-3-4	59	.055	\$	1-3-4-5-6
14	.090	m	5	60	.100	Em Leader	2-3-4-5-6
15	.050	f	1-5	61	.090	E	1-2-3-4-5-6
16	.090	w	2-5	62	.080	T	7
17	.060	y	1-2-5	63	.090	A	1-7
18	.060	p	3-5	64	.080	O	2-7
19	.060	v	1-3-5	65	.060	I	1-2-7
20	.060	b	2-3-5	66	.090	N	3-7
21	.060	g	1-2-3-5	67	.070	S	1-3-7
22	.070	k	4-5	68	.100	H	2-3-7
23	.060	q	1-4-5	69	.090	R	1-2-3-7
24	.040	j	2-4-5	70	.090	D	4-7
25	.070	x	1-2-4-5	71	.080	L	1-4-7
26	.050	z	3-4-5	72	.090	U	2-4-7
27	.060	fi	1-3-4-5	73	.070	C	1-2-4-7
28	.060	fl	2-3-4-5	74	.100	M	3-4-7
29	.070	ff	1-2-3-4-5	75	.080	F	1-3-4-7
30	.090	ffi	6	76	.110	W	2-3-4-7
31	.090	ffi	1-6	77	.090	Y	1-2-3-4-7
32	.090	Em Space	2-6	78	.080	P	5-7
33	.040	Comma	1-2-6	79	.090	V	1-5-7
34	.040	Period	3-6	80	.080	B	2-5-7
35	.050	Colon	1-3-6	81	.080	G	1-2-5-7
36	.050	Semicolon	2-3-6	82	.090	K	3-5-7
37	.060	Interrogation	1-2-3-6	83	.080	Q	1-3-5-7
38	.055	Figure Space	4-6	84	.060	J	2-3-5-7
39	.040	l	1-4-6	85	.090	X	1-2-3-5-7
40	.040	Vertical Rule	2-4-6	86	.070	Z	4-5-7
41	.040	Front Quote	1-2-4-6	87	.090	œ or @	1-4-5-7
42	.050	Exclamation	3-4-6	88	.090	æ or lb	2-4-5-7
43	.040	Hyphen	1-3-4-6	89	.060	Ç	1-2-4-5-7
44	.040	Thin Space	2-3-4-6	90	.090	Em Dash	3-4-5-7
45	.040)	1-2-3-4-6				

**TOOTH COMBINATION CHART
72-CHANNEL AND WIDE 72-CHANNEL MAGAZINE**

CHAN. NO.	CHAN. SIZE	CHAR.	TEETH IN COMBINATION	CHAN. NO.	CHAN. SIZE	CHAR.	TEETH IN COMBINATION
0	.050	e 1st	2	10	.060	d	3-4
1	.050	e	1-2	11	.040	l	1-3-4
2	.050	t	3	12	.070	u	2-3-4
3	.060	a	1-3	13	.060	c	1-2-3-4
4	.050	o	2-3	14	.090	m	5
5	.040	i	1-2-3	15	.050	f	1-5
6	.060	n	4	16	.090	w	2-5
7	.050	s	1-4	17	.060	y	1-2-5
8	.060	h	2-4	18	.060	p	3-5
9	.050	r	1-2-4	19	.060	v	1-3-5

TOOTH COMBINATION CHART

72-CHANNEL AND WIDE 72-CHANNEL MAGAZINE—Continued

CHAN. NO.	CHAN. SIZE	CHAR.	TEETH IN COMBINATION	CHAN. NO.	CHAN. SIZE	CHAR.	TEETH IN COMBINATION
20	.060	b	2-3-5	47	.060	I	1-2-7
21	.060	g	1-2-3-5	48	.090	N	3-7
22	.070	k	4-5	49	.070	S	1-3-7
23	.060	q	1-4-5	50	.100	H	2-3-7
24	.040	j	2-4-5	51	.090	R	1-2-3-7
25	.070	x	1-2-4-5	52	.090	D	4-7
26	.050	z	3-4-5	53	.080	L	1-4-7
27	.040	Comma	1-2-6	54	.090	U	2-4-7
28	.040	Period	3-6	55	.070	C	1-2-4-7
29	.050	Semicolon	2-3-6	56	.100	M	3-4-7
30	.090	Em Space	1-3-4-5	57	.080	F	1-3-4-7
31	.055	1	1-2-5-6	58	.110	W	2-3-4-7
32	.055	2	3-5-6	59	.090	Y	1-2-3-4-7
33	.055	3	1-3-5-6	60	.080	P	5-7
34	.055	4	2-3-5-6	61	.090	V	1-5-7
35	.055	5	1-2-3-5-6	62	.080	B	2-5-7
36	.055	Figure Space	4-6	63	.080	G	1-2-5-7
37	.055	6	4-5-6	64	.090	K	3-5-7
38	.055	7	1-4-5-6	65	.080	Q	1-3-5-7
39	.055	8	2-4-5-6	66	.060	J	2-3-5-7
40	.055	9	1-2-4-5-6	67	.090	X	1-2-3-5-7
41	.055	0	3-4-5-6	68	.070	Z	4-5-7
42	.040	Thin Space	2-3-4-6	69	.040	Hyphen	1-4-5-7
43	.090	E	1-2-3-4-5-6	70	.040	Thin Space	2-4-5-7
44	.080	T	7	71	.040	Apostrophe	1-2-4-5-7
45	.090	A	1-7	72	.055	\$	3-4-5-7
46	.080	O	2-7				

TOOTH COMBINATION CHART

55-CHANNEL ARRANGEMENT OF 72-CHANNEL MAGAZINE

CHAN. NO.	CHAN. SIZE	72-CHAN. CHAR.	55-CHAN. CHAR.	TEETH IN COMBINATION
0	.050	e 1st	o	2
1	.050	e		1-2
2	.050	t	o	3
3	.060	a		1-3
4	.050	o	o	2-3
5	.040	i	f	1-2-3
6	.060	n	Figure Space	4
7	.050	s		1-4
8	.060	h	A	2-4
9	.050	r		1-2-4
10	.060	d	o	3-4
11	.040	l	Thin Space	1-3-4
12	.070	u	n	2-3-4
13	.060	c	i	1-2-3-4
14	.090	m	h	5
15	.050	f	d	1-5
16	.090	w		2-5
17	.060	y	B	1-2-5
18	.060	p	N	3-5
19	.060	v		1-3-5
20	.060	b	c	2-3-5
21	.060	g	w	1-2-3-5
22	.070	k		4-5
23	.060	q	b	1-4-5
24	.040	j	y	2-4-5
25	.070	x		1-2-4-5
26	.050	z	g	3-4-5
27	.040	Comma	Comma	1-2-6
28	.040	Period		3-6

(18) USEFUL MATRIX INFORMATION

TOOTH COMBINATION CHART

55-CHANNEL ARRANGEMENT OF 72-CHANNEL MAGAZINE—Continued

CHAN. NO.	CHAN. SIZE	72-CHAN. CHAR.	55-CHAN. CHAR.	TEETH IN COMBINATION
29	.050	Semicolon	z	2-3-6
30	.090	Em Space	Y	1-3-4-5
31	.055	1	S	1-2-5-6
32	.055	2	q	3-5-6
33	.055	3	Period	1-3-5-6
34	.055	4	E	2-3-5-6
35	.055	5		1-2-3-5-6
36	.055	Figure Space	C	4-6
37	.055	6	x	4-5-6
38	.055	7	G	1-4-5-6
39	.055	8		2-4-5-6
40	.055	9	T	1-2-4-5-6
41	.055	0		3-4-5-6
42	.040	Thin Space	t	2-3-4-6
43	.090	E	M	1-2-3-4-5-6
44	.080	T		7
45	.090	A	p	1-7
46	.080	O	k	2-7
47	.060	I	r	1-2-7
48	.090	N	H	3-7
49	.070	S		1-3-7
50	.100	H	Q	2-3-7
51	.090	R	s	1-2-3-7
52	.090	D	K	4-7
53	.080	L	Hyphen	1-4-7
54	.090	U	Y	2-4-7
55	.070	C	i	1-2-4-7
56	.100	M	m	3-4-7
57	.080	F	J	1-3-4-7
58	.110	W	D	2-3-4-7
59	.090	Y	V	1-2-3-4-7
60	.080	P	F	5-7
61	.090	V	J	1-5-7
62	.080	B	W	2-5-7
63	.080	G		1-2-5-7
64	.090	K	L	3-5-7
65	.080	Q	u	1-3-5-7
66	.060	J	P	2-3-5-7
67	.090	X		1-2-3-5-7
68	.070	Z	R	4-5-7
69	.040	Hyphen	i	1-4-5-7
70	.040	Thin Space		2-4-5-7
71	.040	Apostrophe	U	1-2-4-5-7
72	.055	\$		3-4-5-7

TOOTH COMBINATION CHART

COMMERCIAL FRACTIONS

90-Channel Magazine, Diagram No. 2 or 11

When commercial fractions are run in the magazine they usually displace other characters, as follows:

CHAR.	CHAN.	CHAN. SIZE	TEETH IN COMBINATION	CHAR.	CHAN. SIZE	TEETH IN COMBINATION
1/8	ffi	.090	6	5/8	Z	4-5-7
1/4	ffl	.090	1-6	3/4	tb	2-4-5-7
3/8	Interrogation	.060	1-2-3-6	7/8	&	1-2-4-5-7
1/2	Asterisk	.055	2-5-6			

TOOTH COMBINATION CHART
28-CHANNEL AUXILIARY MAGAZINE

CHAN. NO.	CHAN. SIZE	CHAR.	TEETH IN COMBINATION	CHAN. NO.	CHAN. SIZE	CHAR.	TEETH IN COMBINATION
1	.070	A	1-3-4-5-7	15	.070	K	3-4-6-7
2	.070	O	1-2-3-4-5-7	16	.070	Y	2-3-4-6-7
3	.070	H	6-7	17	.070	E	1-3-4-6-7
4	.070	V	1-6-7	18	.070	S	1-2-3-4-6-7
5	.070	B	2-6-7	19	.070	L	5-6-7
6	.070	P	1-2-6-7	20	.070	Z	1-5-6-7
7	.070	I	3-6-7	21	.070	F	2-5-6-7
8	.070	W	1-3-6-7	22	.070	T	1-2-5-6-7
9	.070	C	2-3-6-7	23	.070	M	3-5-6-7
10	.070	Q	1-2-3-6-7	24	.070	Period	2-3-5-6-7
11	.070	J	4-6-7	25	.070	G	1-3-5-6-7
12	.070	X	1-4-6-7	26	.070	U	1-2-3-5-6-7
13	.070	D	2-4-6-7	27	.070	N	4-5-6-7
14	.070	R	1-2-4-6-7	28	.070	Comma	1-4-5-6-7

34-CHANNEL AUXILIARY MAGAZINE

CHAN. NO.	*CHAN. SIZE	CHAR.	TEETH IN COMBINATION	CHAN. NO.	*CHAN. SIZE	CHAR.	TEETH IN COMBINATION
1	.055	1	2-3-4-5-7	18	.050	S	1-3-4-6-7
2	.055	2	1-3-4-5-7	19	.060	H	1-2-3-4-6-7
3	.050	3	1-2-3-4-5-7	20	.050	R	5-6-7
4	.040	4	6-7	21	.060	D	1-5-6-7
5	.040	5	1-6-7	22	.040	L	2-5-6-7
6	.050	6	2-6-7	23	.070	U	1-2-5-6-7
7	.055	7	1-2-6-7	24	.060	C	3-5-6-7
8	.055	8	3-6-7	25	.090	M	2-3-5-6-7
9	.055	9	1-3-6-7	26	.050	F	1-3-5-6-7
10	.055	0	2-3-6-7	27	.090	W	1-2-3-5-6-7
11	.055	Em Sp.	1-2-3-6-7	28	.060	Y	4-5-6-7
12	.050	E	4-6-7	29	.060	P	1-4-5-6-7
13	.050	T	1-4-6-7	30	.060	V	2-4-5-6-7
14	.060	A	2-4-6-7	31	.060	B	1-2-4-5-6-7
15	.050	O	1-2-4-6-7	32	.060	G	3-4-5-6-7
16	.040	I	3-4-6-7	33	.070	K	2-3-4-5-6-7
17	.060	N	2-3-4-6-7	34	.040	J	1-3-4-5-6-7

*Also for Wide 34-Channel Auxiliary Magazine with narrow lug channels.

WIDE 34-CHANNEL AUXILIARY MAGAZINE

CHAN. NO.	CHAN. SIZE	*CHAN. SIZE	CHAR.	TEETH IN COMBINATION	CHAN. NO.	CHAN. SIZE	CHAR.	TEETH IN COMBINATION
1	.055	.090	1	2-3-4-5-7	18	.070	S	1-3-4-6-7
2	.055	.090	2	1-3-4-5-7	19	.100	H	1-2-3-4-6-7
3	.050	.090	3	1-2-3-4-5-7	20	.090	R	5-6-7
4	.040	.090	4	6-7	21	.090	D	1-5-6-7
5	.040	.090	5	1-6-7	22	.080	L	2-5-6-7
6	.050	.090	6	2-6-7	23	.090	U	1-2-5-6-7
7	.055	.090	7	1-2-6-7	24	.070	C	3-5-6-7
8	.055	.090	8	3-6-7	25	.100	M	2-3-5-6-7
9	.055	.090	9	1-3-6-7	26	.080	F	1-3-5-6-7
10	.055	.090	0	2-3-6-7	27	.100	W	1-2-3-5-6-7
11	.055	.090	Em Sp.	1-2-3-6-7	28	.090	Y	4-5-6-7
12	.090		E	4-6-7	29	.080	P	1-4-5-6-7
13	.080		T	1-4-6-7	30	.090	V	2-4-5-6-7
14	.090		A	2-4-6-7	31	.080	B	1-2-4-5-6-7
15	.080		O	1-2-4-6-7	32	.080	G	3-4-5-6-7
16	.060		I	3-4-6-7	33	.090	K	2-3-4-5-6-7
17	.090		N	2-3-4-6-7	34	.060	J	1-3-4-5-6-7

*For Wide 34-Channel Auxiliary Magazine used on Model 28 and on other models where large display faces are to be used exclusively.

TOOTH COMBINATION CHART

ADVERTISING FIGURES

90-Channel Magazine
Diagram No. 32

CHAR.	CHAN.	CHAN. SIZE	TEETH IN COMBINATION
1	fl	.060	2-3-4-5
2	ffi	.090	6
3	ffi	.090	1-6
4	Interrogation	.060	1-2-3-6
5	Vertical Rule	.040	2-4-6
6	Asterisk	.055	2-5-6
7	X	.090	1-2-3-5-7
8	Z	.070	4-5-7
9	@	.090	1-4-5-7
0	ib	.090	2-4-5-7
\$	Exclamation	.050	3-4-6
Period	(.040	1-4-6
Comma)	.040	1-2-3-4-6
#	&	.060	1-2-4-5-7

34-Channel Auxiliary Magazine
Diagram No. 51A (Two Sets of Figures)

CHAR.	CHAN.	*CHAN. SIZE	TEETH IN COMBINATION
1	1	.055	2-3-4-5-7
2	2	.055	1-3-4-5-7
3	3	.050	1-2-3-4-5-7
4	4	.040	6-7
5	5	.040	1-6-7
6	6	.050	2-6-7
7	7	.055	1-2-6-7
8	8	.055	3-6-7
9	9	.055	1-3-6-7
0	0	.055	2-3-6-7
Period	E	.050	4-6-7
Comma	T	.050	1-4-6-7
\$	A	.060	2-4-6-7
#	O	.050	1-2-4-6-7
1	C	.060	3-5-6-7
2	M	.090	2-3-5-6-7
3	F	.050	1-3-5-6-7
4	W	.090	1-2-3-5-6-7
5	Y	.060	4-5-6-7
6	P	.060	1-4-5-6-7
7	V	.060	2-4-5-6-7
8	B	.060	1-2-4-5-6-7

34-Channel Auxiliary Magazine

CHAR.	CHAN.	*CHAN. SIZE	TEETH IN COMBINATION
9	G	.060	3-4-5-6-7
0	K	.070	2-3-4-5-6-7
Period	R	.050	5-6-7
Comma	D	.060	1-5-6-7
\$	L	.040	2-5-6-7
#	U	.070	1-2-5-6-7

*Also for Wide 34-Channel Auxiliary Magazine with narrow lug channels.

28-Channel Auxiliary Magazine
Diagram No. 96 (Two Sets of Figures)

CHAR.	CHAN.	CHAN. SIZE	TEETH IN COMBINATION
1	A	.070	1-3-4-5-7
2	B	.070	2-6-7
3	C	.070	2-3-6-7
4	D	.070	2-4-6-7
5	E	.070	1-3-4-6-7
6	F	.070	2-5-6-7
7	G	.070	1-3-5-6-7
8	H	.070	6-7
9	I	.070	3-6-7
0	J	.070	4-6-7
Period	K	.070	3-4-6-7
Comma	L	.070	5-6-7
\$	M	.070	3-5-6-7
#	N	.070	4-5-6-7
1	O	.070	1-2-3-4-5-7
2	P	.070	1-2-6-7
3	Q	.070	1-2-3-6-7
4	R	.070	1-2-4-6-7
5	S	.070	1-2-3-4-6-7
6	T	.070	1-2-5-6-7
7	U	.070	1-2-3-5-6-7
8	V	.070	1-6-7
9	W	.070	1-3-6-7
0	X	.070	1-4-6-7
Period	Y	.070	2-3-4-6-7
Comma	Z	.070	1-5-6-7
\$	Period	.070	2-3-5-6-7
#	Comma	.070	1-4-5-6-7

34-CHANNEL WIDE AUXILIARY MAGAZINE
Diagram No. 51A (Two Sets of Figures)

CHAR.	CHAN.	CHAN. SIZE	†CHAN. SIZE	TEETH IN COMBINATION	CHAR.	CHAN.	CHAN. SIZE	TEETH IN COMBINATION
1	1	.055	.090	2-3-4-5-7	1	C	.070	3-5-6-7
2	2	.055	.090	1-3-4-5-7	2	M	.100	2-3-5-6-7
3	3	.050	.090	1-2-3-4-5-7	3	F	.080	1-3-5-6-7
4	4	.040	.090	6-7	4	W	.100	1-2-3-5-6-7
5	5	.040	.090	1-6-7	5	Y	.090	4-5-6-7
6	6	.050	.090	2-6-7	6	P	.080	1-4-5-6-7
7	7	.055	.090	1-2-6-7	7	V	.090	2-4-5-6-7
8	8	.055	.090	3-6-7	8	B	.080	1-2-4-5-6-7
9	9	.055	.090	1-3-6-7	9	G	.080	3-4-5-6-7
0	0	.055	.090	2-3-6-7	0	K	.090	2-3-4-5-6-7
Period	E	.090		4-6-7	Period	R	.090	5-6-7
Comma	T	.080		1-4-6-7	Comma	D	.090	1-5-6-7
\$	A	.090		2-4-6-7	\$	L	.080	2-5-6-7
#	O	.080		1-2-4-6-7	#	U	.090	1-2-5-6-7

†For Wide 34-Channel Auxiliary Magazine used on Model 28 and on other models where large display faces are to be used exclusively.

Face Identification Numbers

Matrices are marked on the sides for the purpose of easy identification as follows: 6Δ8, 6Δ9, 8Δ12, etc. The triangle is a trade-mark and has nothing whatever to do with the identification of the font and face. The figure on the left of the triangle indicates the point size and the figure on the right indicates the name of the face and not its number. Thus, for instance, 10Δ8 does not mean 10 point No. 8, but 10 point Caslon with Italic and Small Caps; 8Δ12 does not mean 8 point No. 12 but, 8 point Cheltenham with Italic and Small Caps. These reference marks will be found convenient for ordering sorts for fonts already in use. If in doubt when ordering sorts, send a sample, lower-case "n," with order.

ONE-LETTER

5½ POINT

TRIANGLE NO.

NAME OF FACE

- 5½ Δ 1 Borders
5½ Δ 17 Bold Face No. 1, Depressed

6 POINT

- 6 Δ 1 Borders
6 Δ 17 Hebrew
6 Δ 43 Greek No. 1 (Part Font)
6 Δ 45 Bold Face No. 3, Figures
6 Δ 49 No. 2 Vertical Slug Table Mats
6 Δ 53 Gothic Condensed No. 2
6 Δ 57 Bold Face No. 1, Figures
6 Δ 59 Gothic No. 3, Figures
6 Δ 97 Gothic Condensed No. 4
6 Δ 123 Gothic Condensed No. 2 (Vertical Slug) Caps
6 Δ 125 Gothic No. 16, Figures

7 POINT

- 7 Δ 27 Bold Face No. 3, Figures
7 Δ 31 Bold Face No. 1, Figures
7 Δ 43 Gothic Condensed No. 1 (Figures)
7 Δ 51 Borders
7 Δ 61 Gothic No. 13 (6 point slug) Caps only

8 POINT

- 8 Δ 1 Borders
8 Δ 21 Greek No. 1 (High Alignment)
8 Δ 39 Gothic Condensed No. 2
8 Δ 59 Celtic No. 1
8 Δ 69 Gothic Condensed No. 1
8 Δ 71 Hebrew
8 Δ 87 Greek No. 1
8 Δ 101 Russian Church
8 Δ 105 Bold Face No. 6, Figures
8 Δ 133 Bold Face No. 9, Figures

(22) USEFUL MATRIX INFORMATION

TRIANGLE NO.	NAME OF FACE
8△151	Lino Text
8△157	Gothic No. 41, Figures
8△159	Gothic No. 16, Figures

9 POINT

9△23	Borders
9△29	Hebrew No. 2
9△31	Modern Hebrew

10 POINT

10△1	Borders
10△19	German No. 2
10△23	Greek No. 1
10△41	Gothic Condensed No. 2
10△69	Gothic Condensed No. 1
10△75	Bold Face No. 3, Figures
10△91	Caslon Text
10△101	Condensed Outline
10△103	Bold Face No. 6, Figures
10△115	Gothic No. 38
10△123	Narciss
10△125	Lino Text
10△131	Card Italic
10△137	Gothic Condensed No. 2 (Vertical Slug) Caps
10△139	Gothic No. 16
10△143	Gothic No. 41, Figures

11 POINT

11△17	Gothic Condensed No. 1
11△31	Bold Face No. 3, Figures
11△37	Hebrew No. 2
11△45	Russian Church
11△49	Hebrew No. 2 (10 point Alignment) Special for English
11△51	Hebrew No. 2 (12 point Alignment) Special for English

12 POINT

12△13	Gothic Condensed No. 1
12△17	Gothic Condensed No. 2
12△29	Caslon Text
12△41	Greek No. 1 (Part Font)
12△53	Bold Face No. 3, Figures
12△65	Gothic No. 18
12△69	Condensed Outline
12△75	Bold Face No. 6, Figures
12△79	Hebrew
12△81	Hebrew Condensed
12△85	Borders
12△105	Jacobite
12△109	Lino Text
12△121	Nestorian
12△127	Narciss
12△129	Gothic No. 38
12△141	Card Italic
12△153	Gothic Condensed No. 2 (Vertical Slug), Caps

TRIANGLE NO. NAME OF FACE

- 12Δ 157 Devanagari
 12Δ 163 Gothic No. 16
 12Δ 167 Gothic No. 41, Figures
 12Δ 169 Gujarati
 12Δ 175 Porson Greek

14 POINT

- 14Δ 3 Gothic Condensed No. 2
 14Δ 5 Gothic Condensed No. 1
 14Δ 7 Century Bold, Roman, Advertising Figures
 14Δ 9 Gothic No. 16, Advertising Figures
 14Δ 11 Mid Gothic, Advertising Figures
 14Δ 13 Cheltenham Bold, Advertising Figures
 14Δ 33 Gothic No. 18
 14Δ 39 Cheltenham Bold Condensed, Advertising Figures
 14Δ 43 Cheltenham Bold Extra Condensed
 14Δ 61 Gothic No. 13, Advertising Figures
 14Δ 63 Cheltenham Italic, Advertising Figures
 14Δ 65 Bold Face No. 6, Advertising Figures
 14Δ 67 Arabic
 14Δ 77 Gothic Relief, Cap Font
 14Δ 79 Russian Church
 14Δ 83 Arabic Bold
 14Δ 85 Narciss
 14Δ 87 Gothic No. 38
 14Δ 89 Arabic Old Style
 14Δ 91 Arabic Bold Old Style
 14Δ 95 Lino Text
 14Δ 97 Card Italic
 14Δ 103 Borders
 14Δ 117 Caslon Bold Condensed
 14Δ 119 Gothic No. 16
 14Δ 121 Gothic No. 41, Figures
 14Δ 129 Memphis Bold, Advertising Figures
 14Δ 131 Cheltenham Bold Condensed, Vertical Slug, Cap Font

TWO-LETTER**4 POINT**

- 4Δ 2 Century Expanded with Gothic No. 16

4¾ POINT

- 4¾ Δ 2 No. 6 with Gothic 16

5 POINT

- 5Δ 2 No. 10 with Gothic No. 4
 5Δ 4 No. 1 with Gothic Condensed No. 1, Figures
 5Δ 6 Special Gothic No. 9 D. C., Figures
 5Δ 8 No. 10 with Italic and Small Caps
 5Δ 10 Gothic No. 9 D. C., Figures
 5Δ 14 No. 22 with Special Gothic No. 9, Figures
 5Δ 18 No. 18 with Antique Black No. 1
 5Δ 20 Old Style No. 1 with Cheltenham Bold
 5Δ 24 Ionic No. 5 with Bold Face No. 2

(24) USEFUL MATRIX INFORMATION

TRIANGLE NO.	NAME OF FACE
5Δ26	Ionic No. 5 with Italic and Small Caps
5Δ28	Caslon No. 3 with Italic and Small Caps
5Δ30	Old Style No. 1 with Italic and Small Caps
5Δ32	Excelsior with Bold Face No. 2
5Δ34	Hebrew Light and Bold
5Δ36	Excelsior with Gothic No. 3
5Δ38	Caslon Bold with Italic

5 1/2 POINT

5 1/2 Δ 2	No. 2 with Bold Face No. 2
5 1/2 Δ 4	No. 1 with Italic and Small Caps
5 1/2 Δ 8	No. 1 with Clarendon No. 1
5 1/2 Δ 10	No. 1 with Bold Face No. 1, Figures
5 1/2 Δ 12	No. 1 with Bold Face No. 2, Figures
5 1/2 Δ 24	No. 11 with Gothic Condensed No. 4
5 1/2 Δ 26	No. 3 Figures, duplicate character
5 1/2 Δ 28	Gothic No. 17 with Bold Face No. 2, Figures
5 1/2 Δ 32	No. 4 with Bold Face No. 2 Condensed
5 1/2 Δ 36	No. 2B with Bold Face No. 2B
5 1/2 Δ 38	Special Gothic No. 9, Figures, duplicate character
5 1/2 Δ 42	Ionic No. 5 with Bold Face No. 2
5 1/2 Δ 44	Ionic No. 5 with Italic and Small Caps
5 1/2 Δ 48	Excelsior with Bold Face No. 2
5 1/2 Δ 50	Excelsior with Italic and Small Caps
5 1/2 Δ 52	Teletype Ionic No. 5 with Bold Face No. 2
5 1/2 Δ 54	Excelsior with Gothic No. 3
5 1/2 Δ 62	Teletype Excelsior with Bold Face No. 2
5 1/2 Δ 64	Ionic No. 5 with Gothic No. 16
5 1/2 Δ 66	Paragon with Paragon Bold

6 POINT

6Δ2	No. 1 with Italic and Small Caps
6Δ4	No. 2 with Italic and Small Caps
6Δ6	No. 2 with Gothic No. 3
6Δ8	Old Style No. 1 with Italic and Small Caps
6Δ12	No. 1 with Bold Face No. 2
6Δ14	Old Style No. 1 with Antique No. 1
6Δ16	Ronaldson with Italic and Small Caps
6Δ18	German No. 3 with Bold Face No. 2
6Δ20	Classic with Italic and Small Caps
6Δ24	De Vinne with Italic and Small Caps
6Δ28	De Vinne with Antique No. 3
6Δ30	Ronaldson with Antique No. 1
6Δ32	No. 12 with Gothic No. 8
6Δ36	No. 1 with Gothic No. 2, Figures
6Δ38	No. 12 Figures with Old Style Small Caps
6Δ42	Century Expanded with Italic and Small Caps
6Δ44	De Vinne with Gothic No. 7, Figures
6Δ46	No. 1 with Bold Face No. 1, Figures
6Δ48	No. 1 with Clarendon No. 1, Figures
6Δ50	No. 2 with Antique No. 2
6Δ56	No. 2 with Gothic No. 6 (Vertical Slug) Table Matrices
6Δ58	Russian No. 8 with Italic

TRIANGLE NO.	NAME OF FACE
6Δ62	No. 16 with Italic and Small Caps
6Δ70	No. 2 with Bold Face No. 1
6Δ74	No. 28 with Antique Black No. 1
6Δ76	No. 10 with Gothic No. 4
6Δ82	No. 2 with Gothic Condensed No. 2, Figures
6Δ86	Original Old Style with Italic and Small Caps
6Δ88	No. 21 with Antique No. 6, Figures
6Δ90	Old Style No. 1 with Title No. 1
6Δ92	Ronaldson with Title No. 1
6Δ94	Century Expanded with Century Bold
6Δ96	Scotch with Italic and Small Caps
6Δ98	Antique No. 1 with Italic
6Δ100	No. 1 with Gothic No. 8, Figures
6Δ102	Old Style No. 3 with Italic and Small Caps
6Δ110	No. 16 with Century Bold
6Δ112	Old Style No. 1 with Title No. 2
6Δ114	Ronaldson with Title No. 2
6Δ116	Special Gothic No. 9 Figures, duplicate character
6Δ118	No. 2 with Condensed Title No. 3
6Δ120	No. 11 with Gothic Condensed No. 4
6Δ122	No. 8 with Bold Face No. 2
6Δ124	Old Style No. 1 with Cheltenham Bold
6Δ128	Ronaldson with Cheltenham Bold
6Δ132	No. 17 with Condensed Title No. 5
6Δ150	No. 21 with Italic and Small Caps
6Δ152	Servian No. 8 with Italic
6Δ154	No. 2 D. C. Vertical Slug Table Matrices
6Δ156	Bodoni Bold with Italic
6Δ158	Bodoni with Italic and Small Caps
6Δ160	Caslon No. 3 with Italic and Small Caps
6Δ162	Cheltenham Bold with Italic
6Δ164	Gothic No. 25A with 6 point Gothic Condensed No. 2, Caps and Figures
6Δ166	Gothic No. 25B with 8 point Gothic Condensed No. 2, Caps and Figures
6Δ168	Gothic No. 25C with 6 point Gothic No. 26C, Caps and Figures
6Δ170	Gothic No. 25 with 6 point Gothic No. 26, Caps and Figures
6Δ172	Century Expanded with Cheltenham Bold
6Δ174	Greek No. 3
6Δ176	No. 11B with Gothic Condensed No. 4B
6Δ180	Cheltenham Wide with Cheltenham Bold
6Δ184	Borders
6Δ186	No. 2 with Bold Face No. 2
6Δ188	Armenian No. 1 with No. 2
6Δ192	Bodoni Book with Italic and Small Caps
6Δ194	Old Style No. 7 with Italic and Small Caps
6Δ200	Ronaldson No. 7 with Italic and Small Caps
6Δ202	Caslon No. 2 with Italic and Small Caps
6Δ204	Gothic No. 29 with Gothic No. 30, Caps and Figures
6Δ206	Gothic No. 29C with Gothic No. 30C, Caps and Figures
6Δ208	Gothic No. 29B with Gothic No. 30B, Caps and Figures
6Δ210	Gothic No. 29A with Gothic No. 30A, Caps and Figures
6Δ212	Bold Face No. 9 with Gothic No. 31, Caps and Figures
6Δ214	Bold Face No. 9C with Gothic No. 31C, Caps and Figures
6Δ216	Bold Face No. 9B with Gothic No. 31B, Caps and Figures

(26) USEFUL MATRIX INFORMATION

TRIANGLE NO.	NAME OF FACE
6Δ218	Bold Face No. 9A with Gothic No. 31A, Caps and Figures
6Δ220	Elzevir No. 3 with Italic and Small Caps
6Δ222	No. 1 with Gothic No. 3, Figures, Hebrew alignment
6Δ224	Caslon Old Face with Italic and Small Caps
6Δ226	Royal Gothic Figures, duplicate character
6Δ228	Franklin Old Style with Italic and Small Caps
6Δ232	Cheltenham Bold Condensed with Italic
6Δ236	Gothic No. 32 with Gothic No. 33, Caps and Figures
6Δ238	Gothic No. 32A with Gothic No. 33A, Caps and Figures
6Δ240	Gothic No. 32B with Gothic No. 33B, Caps and Figures
6Δ242	Gothic No. 32C with Gothic No. 33C, Caps and Figures
6Δ244	Benedictine with Italic and Small Caps
6Δ248	Gothic No. 31 with Gothic No. 33, Caps and Figures
6Δ250	Benedictine Book with Italic and Small Caps
6Δ252	Gothic No. 31A with Gothic No. 33A, Caps and Figures
6Δ254	Gothic No. 31B with Gothic No. 33B, Caps and Figures
6Δ256	Gothic No. 31 with Gothic No. 32, Caps and Figures
6Δ258	Gothic No. 31A with Gothic No. 32A, Caps and Figures
6Δ260	Gothic No. 31B with Gothic No. 32B, Caps and Figures
6Δ262	Gothic No. 31C with Gothic No. 32C, Caps and Figures
6Δ264	Benedictine Book with Benedictine
6Δ268	Cloister Bold with Italic
6Δ270	Gothic No. 31C with Gothic No. 33C, Caps and Figures
6Δ274	Garamond with Italic and Small Caps
6Δ276	Cloister Wide with Cloister Bold
6Δ280	Cloister with Italic and Small Caps
6Δ286	Garamond Bold with Italic
6Δ288	Ionic No. 5 with Bold Face No. 2
6Δ290	Hebrew with Italic
6Δ296	Textype with Bold Face No. 2
6Δ298	Metroblack with Metrolite
6Δ300	Metromedium with Metrothin
6Δ302	Ionic No.5 with Italic and Small Caps
6Δ304	Textype with Italic and Small Caps
6Δ306	Granjon with Granjon Bold
6Δ310	Metroblack No. 2 with Metrolite No. 2
6Δ312	Metromedium No. 2 with Metrothin No. 2
6Δ314	Excelsior with Bold Face No. 2
6Δ320	Excelsior with Italic and Small Caps
6Δ322	Memphis Light and Bold
6Δ324	Teletype Excelsior with Gothic No. 3
6Δ326	Memphis Medium with Italic
6Δ364	Memphis Bold with Italic
6Δ366	Excelsior with Gothic No. 3
6Δ368	Memphis Light with Italic
6Δ372	Granjon with Italic and Small Caps
6Δ374	Teletype Excelsior with Bold Face No. 2
6Δ376	Lining Metromedium with Lining Metrothin, Caps and Figures
6Δ378	Lining Metromedium A with Lining Metrothin A, Caps and Figures
6Δ380	Lining Metromedium B with Lining Metrothin B, Caps and Figures
6Δ382	Lining Memphis Light with Lining Memphis Bold, Caps and Figures
6Δ384	Lining Memphis Light A with Lining Memphis Bold A, Caps and Figures
6Δ386	Lining Memphis Light B with Lining Memphis Bold B, Caps and Figures

TRIANGLE NO.	NAME OF FACE
6Δ388	Paragon with Paragon Bold
6Δ390	Paragon with Italic and Small Caps
6Δ392	Metromedium No. 2 with Italic
6Δ394	Bookman with Italic and Small Caps
6Δ396	Garamond Bold No. 3 with Italic
6Δ398	Garamond No. 3 with Italic and Small Caps
6Δ410	Caslon Bold with Italic
6Δ414	Lining Card Gothic Medium with Bold, Caps and Figures
6Δ416	Memphis Medium with Memphis Bold
6Δ418	Bell Gothic, Two-Letter
6Δ420	Opticon with Bold Face No. 2
6Δ422	Teletype No. 2 with Condensed Title No. 3
6Δ424	Opticon with Italic and Small Caps
6Δ426	Excelsior with Memphis Bold
6Δ432	Teletype Paragon with Paragon Bold
6Δ434	Metrolite No. 2 with Italic
6Δ436	Metrolite No. 2 with Italic
6Δ668	Granjon with Italic and Small Caps

6½ POINT

6½Δ2	Ionic No. 5 with Bold Face No. 2
6½Δ6	Ionic No. 5 with Italic and Small Caps
6½Δ8	Teletype Ionic No. 5 with Bold Face No. 2

6¾ POINT

6¾Δ2	Ionic No. 5 with Bold Face No. 2
6¾Δ4	Ionic No. 5 with Italic and Small Caps

7 POINT

7Δ2	No. 2 with Bold Face No. 1
7Δ4	No. 1 with Italic and Small Caps
7Δ6	No. 16 with Italic and Small Caps
7Δ8	Caslon with Italic and Small Caps
7Δ10	Ronaldson with Italic and Small Caps
7Δ14	Old Style No. 1 with Italic and Small Caps
7Δ22	No. 28 with Antique Black No. 1
7Δ28	No. 1 with Doric No. 1 (Part Font)
7Δ30	No. 2 with Gothic No. 3
7Δ38	No. 1 with Bold Face No. 1, Figures
7Δ42	No. 1 with Gothic No. 4
7Δ46	No. 2 with Italic and Small Caps
7Δ48	Old Style No. 1 with Antique No. 1
7Δ50	No. 16 with Century Bold
7Δ52	Bold Face No. 3 Figures, duplicate character
7Δ58	No. 2 with Antique Black No. 1, Figures
7Δ60	Gothic No. 4 Figures, duplicate character
7Δ62	No. 2 with Condensed Title No. 3
7Δ66	No. 21 with Italic and Small Caps
7Δ74	No. 2 with Gothic No. 8, Figures
7Δ80	Century Expanded with Century Bold
7Δ84	Borders
7Δ86	No. 2 with Bold Face No. 2
7Δ88	Century Expanded with Italic and Small Caps

(28) USEFUL MATRIX INFORMATION

TRIANGLE NO.	NAME OF FACE
7△90	No. 1 with Bold Face No. 2
7△92	Bodoni with Italic and Small Caps
7△94	Bodoni Book with Italic and Small Caps
7△96	Old Style No. 7 with Italic and Small Caps
7△98	Franklin Old Style with Italic and Small Caps
7△102	No. 21 with Gothic No. 4
7△104	Benedictine with Italic and Small Caps
7△110	Benedictine Book with Italic and Small Caps
7△118	No. 12 with Gothic No. 11
7△120	Benedictine Book with Benedictine
7△122	Ionic No. 5 with Bold Face No. 2
7△126	Ionic No. 5 with Italic and Small Caps
7△130	Textype with Bold Face No. 2
7△132	Textype with Italic and Small Caps
7△136	No. 2 Excelsior with Bold Face No. 2
7△138	No. 1 Excelsior with Bold Face No. 2
7△140	No. 1 Excelsior with Italic and Small Caps
7△142	No. 2 Excelsior with Italic and Small Caps
7△144	Teletype No. 1 Excelsior with Bold Face No. 2
7△148	Ronaldson No. 7 with Italic and Small Caps
7△150	Teletype Ionic No. 5 with Bold Face No. 2
7△152	No. 21B with Italic and Small Caps
7△154	Caslon No. 3 with Italic and Small Caps
7△156	No. 1 Excelsior with Gothic No. 3
7△158	No. 2 Excelsior and Gothic No. 3
7△160	Teletype No. 1 Excelsior with Gothic No. 3
7△162	Paragon with Paragon Bold
7△164	Paragon with Italic and Small Caps
7△166	Opticon with Bold Face No. 2
7△168	Caslon No. 137 with Italic and Small Caps
7△170	Bookman with Italic and Small Caps
7△172	Garamond No. 3 with Italic and Small Caps
7△174	Garamond Bold No. 3 with Italic
7△176	Bodoni Bold with Italic
7△182	Electra with Italic and Small Caps
7△184	Baskerville with Italic and Small Caps
7△186	Teletype Paragon with Paragon Bold
7△188	Bell Gothic, Two-Letter

7½ POINT

7½△2	Ionic No. 5 with Bold Face No. 2
7½△4	Ionic No. 5 with Italic and Small Caps
7½△6	Excelsior with Bold Face No. 2
7½△8	Excelsior with Italic and Small Caps
7½△10	Opticon with Bold Face No. 2
7½△12	Teletype Ionic No. 5 with Bold Face No. 2
7½△16	Opticon with Italic
7½△18	Paragon with Paragon Bold
7½△20	Paragon with Italic and Small Caps

7¾ POINT

7¾△2	Excelsior with Bold Face No. 2
------	--------------------------------

8 POINT

TRIANGLE NO.	NAME OF FACE
8Δ2	No. 2 with Italic and Small Caps, high alignment
8Δ4	No. 2 with Gothic No. 6 (Vertical Slug), Figures
8Δ6	No. 2 with Condensed Title No. 3
8Δ8	No. 2 with Bold Face No. 1, high alignment
8Δ10	No. 1 with Italic and Small Caps, high alignment
8Δ12	Cheltenham with Italic and Small Caps
8Δ16	De Vinne with Antique No. 3, high alignment
8Δ18	De Vinne with Italic and Small Caps, high alignment
8Δ20	German No. 3 with Bold Face No. 2
8Δ24	Caslon with Italic and Small Caps
8Δ26	Century Expanded with Italic and Small Caps
8Δ28	Classic with Italic and Small Caps
8Δ30	Old Style No. 1 with Italic and Small Caps
8Δ32	Remington Typewriter with Underscore
8Δ34	Ronaldson with Italic and Small Caps
8Δ36	Ronaldson with Antique No. 1
8Δ38	No. 19 with Italic and Small Caps, high alignment
8Δ40	No. 19 with Title No. 1, high alignment
8Δ42	Scotch with Italic and Small Caps, high alignment
8Δ44	Title No. 2 with Title Italic No. 2
8Δ48	No. 28 with Italic and Small Caps
8Δ50	Old Style No. 1 with Antique No. 1
8Δ52	No. 28 with Antique Black No. 1
8Δ54	No. 16 with Italic and Small Caps
8Δ56	No. 28 with Egyptienne Serree No. 1
8Δ58	Russian No. 11 with Antique Black No. 2
8Δ60	Cheltenham Bold with Italic
8Δ70	No. 2 with Gothic No. 3, high alignment
8Δ72	No. 4 Figures with Clarendon No. 1 Figures, high alignment
8Δ74	No. 4 Figures with Clarendon No. 1
8Δ80	No. 2 with Ionic No. 3 (Vertical Slug), Figures
8Δ82	Scotch with Italic and Small Caps
8Δ88	No. 2, high alignment, with 10 point Clarendon No. 1
8Δ92	No. 28 with Normande No. 4
8Δ94	Russian Condensed No. 2 with Antique Black No. 2
8Δ96	Russian Condensed No. 2 with Italic
8Δ98	No. 1 with Italic and Small Caps
8Δ102	No. 4 Figures with Old Style Small Caps
8Δ104	Elzevir with Cheltenham Bold
8Δ108	Classic with Century Bold
8Δ110	Russian No. 11 with Italic
8Δ114	Antique No. 1 with Italic
8Δ116	Old Style No. 3 with Italic and Small Caps
8Δ118	De Vinne with Italic and Small Caps
8Δ120	Russian No. 3 Light and Bold
8Δ122	Century Expanded with Century Bold
8Δ126	No. 26 with Antique No. 2
8Δ128	No. 16 with Century Bold
8Δ130	Gothic No. 8 Figures, duplicate character
8Δ132	No. 1 with Gothic Condensed No. 2, Figures, high alignment
8Δ134	Old Style No. 1 with Title No. 1

(30) USEFUL MATRIX INFORMATION

TRIANGLE NO.	NAME OF FACE
8Δ136	Ronaldson with Title No. 1
8Δ138	Original Old Style with Italic and Small Caps
8Δ140	No. 21 with Antique No. 6, Figures
8Δ150	Greek No. 3
8Δ152	Old Style No. 1 with Antique Italic No. 1
8Δ154	Ronaldson with Antique Italic No. 1
8Δ156	Cheltenham Wide with Cheltenham Bold
8Δ160	Old Style No. 4 with Antique No. 2
8Δ162	Scotch with Jenson
8Δ164	De Vinne with Antique No. 3
8Δ166	Cheltenham Condensed with Cheltenham Bold Condensed
8Δ174	No. 19 with Title No. 1
8Δ176	Cheltenham Bold Condensed with Italic
8Δ186	Servian Condensed No. 2 with Italic
8Δ188	Servian No. 11 with Italic
8Δ190	Armenian No. 1 with No. 2
8Δ192	No. 1 with Title No. 2
8Δ194	No. 1 with Bold Face No. 2
8Δ196	Old Style No. 1 with Title No. 2
8Δ200	Ronaldson with Title No. 2
8Δ204	Gothic No. 13 with De Vinne Condensed
8Δ206	Gothic No. 16 with Title No. 4
8Δ208	Caslon No. 3 with Italic and Small Caps
8Δ210	No. 2 with Bold Face No. 1, Figures
8Δ212	Old Style No. 7 with Italic and Small Caps
8Δ214	No. 21 with Italic and Small Caps
8Δ218	Old Style No. 1 with Cheltenham Bold
8Δ220	Old Roman with Italic
8Δ222	Bodoni Bold with Italic
8Δ224	Ronaldson with Cheltenham Bold
8Δ228	Ronaldson No. 7 with Italic and Small Caps
8Δ230	De Vinne with 7 point Century Bold
8Δ234	De Vinne with Title No. 1
8Δ238	Servian Condensed No. 2 with Antique Black No. 2
8Δ240	No. 2 with Gothic No. 8, Figures
8Δ242	No. 17 with Condensed Title No. 5
8Δ250	Servian No. 3 Light and Bold
8Δ252	No. 2 with Italic and Small Caps
8Δ254	Century Expanded with Cheltenham Bold
8Δ256	No. 2 D. C. (Vertical Slug), Figures
8Δ258	Servian No. 11 with Antique Black No. 2
8Δ260	Gothic No. 16 Figures, duplicate character
8Δ262	Bodoni with Italic and Small Caps
8Δ266	Gothic No. 25 with Gothic No. 26
8Δ274	Benedictine with Italic and Small Caps
8Δ276	De Vinne (Vertical Slug), Figures
8Δ280	Bodoni Book with Italic and Small Caps
8Δ282	No. 21 with Antique No. 6, Figures, high alignment
8Δ298	Caslon No. 2 with Italic and Small Caps
8Δ306	Etzevir No. 3 with Italic and Small Caps
8Δ308	Century Bold with Century Bold Italic
8Δ310	Borders
8Δ312	Caslon Old Face with Italic and Small Caps

TRIANGLE NO.	NAME OF FACE
8Δ314	Antique Black No. 1 Figures, duplicate character
8Δ316	Franklin Old Style with Italic and Small Caps
8Δ318	Gothic No. 13 with Cheltenham Bold Condensed
8Δ320	Gothic No. 16 with Cheltenham Bold
8Δ360	Benedictine Book with Italic and Small Caps
8Δ364	Benedictine Bold with Italic
8Δ366	Benedictine Book with Benedictine
8Δ370	Cloister Bold with Italic
8Δ372	Garamond with Italic and Small Caps
8Δ374	Cloister Wide with Cloister Bold
8Δ378	Cloister with Italic and Small Caps
8Δ380	Garamond Bold with Italic
8Δ382	Ionic No. 5 with Bold Face No. 2
8Δ384	Ionic No. 5 with Italic and Small Caps
8Δ386	Granjon with Italic and Small Caps
8Δ394	Textype with Bold Face No. 2
8Δ396	Textype with Italic and Small Caps
8Δ408	Hebrew with Italic
8Δ410	Metroblack with Metralite
8Δ412	Poster Bodoni with Italic
8Δ414	Metromedium with Metrothin
8Δ416	Scotch No. 2 with Italic and Small Caps
8Δ418	Granjon with Granjon Bold
8Δ420	Baskerville with Italic and Small Caps
8Δ422	Remington No. 2 with Remington No. 3
8Δ424	No. 1 Excelsior with Bold Face No. 2
8Δ426	Metroblack No. 2 with Metralite No. 2
8Δ428	Metromedium No. 2 with Metrothin No. 2
8Δ432	No. 1 Excelsior with Italic and Small Caps
8Δ434	Tariff Typewriter
8Δ436	Janson with Italic and Small Caps
8Δ440	No. 2 Excelsior with Bold Face No. 2
8Δ442	Memphis Light and Bold
8Δ444	No. 2 Excelsior with Italic and Small Caps
8Δ446	Estienne with Italic and Small Caps
8Δ448	Memphis Bold with Italic
8Δ450	Memphis Light with Italic
8Δ452	Ionic No. 4 with Antique No. 8
8Δ454	Ionic No. 4 with Antique No. 8, Self Spacing
8Δ456	Memphis Medium with Italic
8Δ462	Paragon with Paragon Bold
8Δ464	Paragon with Italic and Small Caps
8Δ466	Caslon No. 137 with Italic and Small Caps
8Δ468	No. 2 Excelsior with Gothic No. 3
8Δ470	Bookman with Italic and Small Caps
8Δ476	Garamond No. 3 with Italic and Small Caps
8Δ478	Garamond Bold No. 3 with Italic
8Δ480	Teletype No. 1 Excelsior with Bold Face No. 2
8Δ482	Opticon with Bold Face No. 2
8Δ484	Electra with Italic and Small Caps
8Δ488	Memphis Medium with Memphis Bold
8Δ490	Gothic No. 44 with Gothic No. 42, Figures
8Δ492	Gothic No. 45 with Gothic No. 43, Figures

(32) USEFUL MATRIX INFORMATION

TRIANGLE NO.	NAME OF FACE
8Δ494	Metromedium No. 2 with Italic
8Δ496	Opticon with Italic and Small Caps
8Δ500	Teletype No. 2 with Condensed Title No. 3
8Δ502	Excelsior with Memphis Bold
8Δ504	Erbar Light Condensed with Erbar Bold Condensed
8Δ506	Memphis Extra Bold with Italic
8Δ508	Bell Gothic, Two-Letter
8Δ510	Greek Metralite, Two-Letter
8Δ512	Metroblack No. 2 with Italic
8Δ516	Metrolite No. 2 with Italic
8Δ518	Teletype Ionic No. 5 with Bold Face No. 2
8ΔA18	Estienne with Italic and Small Caps

9 POINT

9Δ2	Old Style No. 1 with Italic and Small Caps
9Δ4	De Vinne with Italic and Small Caps
9Δ6	De Vinne with Antique No. 3
9Δ8	Ronaldson with Italic and Small Caps
9Δ10	German No. 3 with Bold Face No. 2
9Δ12	No. 16 with Italic and Small Caps
9Δ18	Caslon with Italic and Small Caps
9Δ36	Greek No. 2
9Δ38	Greek Bold Face No. 1
9Δ42	De Vinne with 10 point Gothic No. 4, 11 point alignment
9Δ44	No. 1 with Italic and Small Caps
9Δ46	Cheltenham with Italic and Small Caps
9Δ48	Old Style No. 1 with Antique No. 1
9Δ50	Greek Elzevir
9Δ52	Ronaldson with Antique No. 1
9Δ56	No. 16 with Century Bold
9Δ58	Century Expanded with Italic and Small Caps
9Δ60	No. 21 with Italic and Small Caps
9Δ62	Old Style No. 7 with Italic and Small Caps
9Δ64	Ronaldson No. 7 with Italic and Small Caps
9Δ72	Century Expanded with Century Bold
9Δ74	Bold Face No. 1 Figures, duplicate character
9Δ78	Elzevir No. 3 with Italic and Small Caps
9Δ82	Caslon Old Face with Italic and Small Caps
9Δ84	Franklin Old Style with Italic and Small Caps
9Δ90	Benedictine with Italic and Small Caps
9Δ94	Benedictine Book with Italic and Small Caps
9Δ100	Benedictine Book with Benedictine
9Δ102	Garamond with Italic and Small Caps
9Δ104	Bodoni Book with Italic and Small Caps
9Δ110	Hebrew No. 2 with Italic No. 3
9Δ112	Ionic No. 5 with Bold Face No. 2
9Δ116	Ionic No. 5 with Italic and Small Caps
9Δ118	Textype with Bold Face No. 2
9Δ120	Hebrew with Hebrew Italic No. 3
9Δ122	Textype with Italic and Small Caps
9Δ126	Scotch No. 2 with Italic and Small Caps
9Δ128	Baskerville with Italic and Small Caps
9Δ130	Caslon No. 3 with Italic and Small Caps

TRIANGLE NO.

NAME OF FACE

- 9△132 Antique No. 1 with Italic
 9△134 Excelsior with Italic and Small Caps
 9△136 Excelsior with Bold Face No. 2
 9△138 Borders
 9△140 Memphis Light with Bold
 9△142 Granjon with Italic and Small Caps
 9△144 Caslon No. 137 with Italic and Small Caps
 9△146 Memphis Medium with Italic
 9△148 Memphis Bold and Italic
 9△150 Bookman with Italic and Small Caps
 9△152 Garamond No. 3 with Italic and Small Caps
 9△154 Garamond Bold No. 3 with Italic
 9△156 Paragon with Italic and Small Caps
 9△158 Paragon with Paragon Bold
 9△160 Electra with Italic and Small Caps
 9△162 Opticon with Bold Face No. 2
 9△164 Teletype Ionic No. 5 with Bold Face No. 2
 9△671 Granjon with Italic and Small Caps

10 POINT

- 10△4 Original Old Style with Italic and Small Caps
 10△6 Old Style No. 1 with Italic and Small Caps
 10△8 Caslon with Italic and Small Caps
 10△10 No. 7 with Italic and Small Caps
 10△12 De Vinne with Antique No. 3
 10△16 Century Expanded with Italic and Small Caps
 10△18 Cheltenham with Italic and Small Caps
 10△22 Classic with Italic and Small Caps
 10△24 De Vinne with Italic and Small Caps
 10△32 Ronaldson with Italic and Small Caps
 10△34 Ronaldson with Antique No. 1
 10△36 Scotch with Italic and Small Caps
 10△38 German No. 3 with Bold Face No. 2
 10△44 Old Style No. 1 with Antique No. 1
 10△46 Russian Old Style with Antique No. 1
 10△48 No. 16 with Italic and Small Caps
 10△52 Servian Old Style with Antique No. 1
 10△54 No. 28 with Italic and Small Caps
 10△56 No. 13 Figures with 10 point Clarendon No. 1 Figures
 10△58 Old Style No. 1 Figures with Clarendon No. 1 Figures
 10△64 De Vinne with Antique No. 3 (Vertical Slug), Figures
 10△66 Russian Condensed No. 2 with Italic
 10△70 Antique No. 3 with 12 point Gothic Condensed No. 1
 10△76 Greek No. 2
 10△78 Greek Bold Face No. 1
 10△80 Russian No. 11 with Antique Black No. 2
 10△82 Cheltenham Bold with Italic
 10△84 Elzevir with Cheltenham Bold
 10△86 Classic with Century Bold
 10△88 Russian No. 11 with Italic
 10△90 Russian Condensed No. 2 with Antique Black No. 2
 10△92 Antique No. 1 with Italic
 10△94 Bold Face No. 3, duplicate character, Figures

(34) USEFUL MATRIX INFORMATION

TRIANGLE NO.	NAME OF FACE
10Δ98	Old Style No. 3 with Italic and Small Caps
10Δ100	De Vinne Figures with Old Style Small Caps
10Δ102	Gothic No. 3 with 11 point Gothic Condensed No. 1
10Δ104	Uniline with Italic and Small Caps
10Δ106	Greek Italic No. 1
10Δ108	Russian No. 3 Light and Bold
10Δ110	Small Russian No. 3 Light and Bold
10Δ112	Century Expanded with Century Bold
10Δ114	No. 2 with Condensed Title No. 3
10Δ116	No. 16 with Century Bold
10Δ120	Old Style No. 1 with Title No. 1
10Δ122	Ronaldson with Title No. 1
10Δ124	No. 21 with Antique No. 6, Figures
10Δ126	Greek No. 3
10Δ128	Old Style No. 1 with Antique Italic No. 1
10Δ130	Ronaldson with Antique Italic No. 1
10Δ132	Egyptienne Serree No. 3 with Normande No. 4
10Δ134	Cheltenham Wide with Cheltenham Bold
10Δ136	Gothic No. 3 with 12 point De Vinne Condensed
10Δ138	Scotch with Jenson
10Δ142	Cheltenham Condensed with Cheltenham Bold Condensed
10Δ146	Armenian No. 1 with No. 2
10Δ148	Cheltenham Bold Condensed with Italic
10Δ152	No. 28 with Antique Black No. 1
10Δ154	Gothic No. 13 with De Vinne Condensed
10Δ156	Gothic No. 16 with Title No. 4
10Δ158	Old Style No. 1 with Cheltenham Bold
10Δ162	No. 2 with Gothic No. 3
10Δ170	Old Style No. 1 with Title No. 2
10Δ174	Ronaldson with Title No. 2
10Δ180	Caslon No. 3 with Italic and Small Caps
10Δ184	Old Style No. 7 with Italic and Small Caps
10Δ186	No. 21 with Italic and Small Caps
10Δ192	Old Roman with Italic
10Δ194	Pabst Old Style with Italic
10Δ196	Bodoni Bold with Italic
10Δ198	Ronaldson with Cheltenham Bold
10Δ200	Ronaldson No. 7 with Italic and Small Caps
10Δ206	De Vinne with Title No. 1
10Δ208	Century Expanded with Cheltenham Bold
10Δ214	Small Servian No. 3, Light and Bold
10Δ216	Servian No. 3, Light and Bold
10Δ218	Bodoni with Italic and Small Caps
10Δ224	Gothic No. 16 Figures, duplicate character, Figures
10Δ226	Century Expanded with Century Bold Italic
10Δ228	Gothic No. 25 with Gothic No. 26, Caps and Figures
10Δ238	Servian No. 11 with Antique Black No. 2
10Δ240	Benedictine with Italic and Small Caps
10Δ244	De Vinne D. C. (Vertical Slug)
10Δ248	Servian No. 11 with Italic
10Δ250	Bodoni Book with Italic and Small Caps
10Δ260	Caslon No. 2 with Italic and Small Caps
10Δ266	Cheltenham Wide with Cheltenham Bold Italic